

✓ Programmable high performance for universal readers



Programmable SM-2570(C) with integrated Application Processor

Programmable Security Module multi-standard SM-2570 / SM-2570C

The flexible „all-in-one“ solution for high performance multi-standard 13.56 MHz contactless smart card applications.

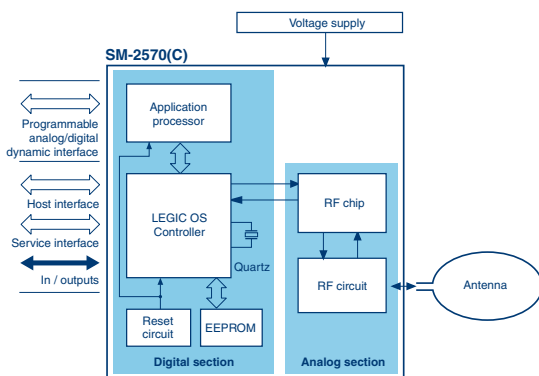

Block diagram

The programmable Security Modules multi-standard SM-2570 and SM-2570C* meet the ISO RF standards ISO 14443 A and ISO 15693 as well as the LEGIC RF standard. The modules can operate all RF standards simultaneously, giving choice of different credentials as well as ensuring backward compatibility with LEGIC prime.

* Option SM-2570C: incl. cash handling functions for e-payment solutions

The SM-2570 is a fully integrated hybrid reader module. It consists of the LEGIC OS Controller, the user programmable on-chip application processor and the LEGIC RF chip. Design-in is made easy due to its integrated RF circuit and the efficient development tools. The programmable analog/digital dynamic interface enables the use of a wide range of peripherals (keyboards, displays etc.). Advanced high security features and various host interfaces offer a comprehensive base for a secure RFID reader platform.

Standards



ISO



LEGIC RF standard



13.56 MHz contactless technology

Key applications



access



ticketing



payment

Typical use

- Universal, high performance readers
- Initialization and personalization devices

Key Features

- Ready-to-use module due to integrated multi-standard RF circuit
- Flexible, user programmable on-chip application processor
- Supports smart card micro-controllers and NFC phones
- Programmable interface supports various peripherals
- Fast and cost efficient design-in – little RF knowledge required
- High security and MTSC – configurable for each application
- Initialization functions for Master-Token and credentials



Features

- **RF standards:** simultaneous operation of all ISO and LEGIC RF standard, reads UID of transponders based on Inside Contactless technology, e.g. HID iClass
- **Reading/writing of transponders:** secure and contactless; transparent mode
- **Smart card µC / NFC phone support:** LEGIC card-in-card solutions
- **Communication range*:** up to 25 cm with standard circuit design
- **Application Processor:** programmable, can hold full application
- **Operating modes:** without, with external or on-chip Application Processor
- **Peripheral interface:** programmable analog/digital dynamic interface, enables the direct use of a wide range of peripherals
- **Host interfaces:** various protocols (e.g. RS232/485, SPI, BPA/L)
- **Application interfaces:** flexible data format generator for Wiegand and OMRON (ABA, Clock & Data)
- **Data transmission:** encrypted along complete data path from transponder memory via RF interface to external host system (end-to-end security)
- **Data encryption:** selectable standards for each application
- **Reader design:** ready-to-use module with integrated RF circuit, programmable Application Processor and interfaces
- **RF wake-up:** watch mode for battery operation
- **Power consumption:** various low power modes, configurable RF power
- **Download function:** firmware upgrades through host or service interface
- **Master-Token System Control:** for authorization, data access and application management
- **Multiapplication:** direct access to specific application; variable segment length and freely selectable segment search criteria
- **Application standards for interoperability:** defined data structures and functions for cash handling, access control, biometrics and others
- **FIPS 201:** reads FASC-N according Transition State Specification
- **Initialization function:** for creating Master-Tokens and to initialize application segments on credentials
- **Backward compatibility:** with LEGIC prime

Typical applications



* Max. reading range depends on used RF standard, the requirements of national spectrum management authorities, antenna, reader application, transponder, requested information and surroundings.

Trademark Disclaimer: INSIDE CONTACTLESS is a registered trademark of Inside Contactless SA. ICLASS is a registered trademark of HID Corporation. LEGIC is not affiliated with or otherwise linked to HID Corporation. HID Corporation neither sponsors nor endorses LEGIC or its products.

Content is subject to change without prior notice.

Specifications

Module and RF circuit	
Carrier frequency	13.56 MHz
Antenna impedance	50 Ohm
Contactless RF standards	ISO 15693, ISO 14443 A, LEGIC RF Standard, Inside
Range*	up to 25 cm
Operating voltage	3.3 to 5 V DC
Power consumption (5 V typical)	215 mA in RF active mode 27 mA in normal operation 30 µA in watch mode < 5 µA in stop mode
Encryption standards	LEGIC encryption, DES, 3DES, host authentication/encryption enable
Direct Host interfaces	serial asynchronous (TTL, RS232, RS485); SPI; separate service interface
Baud rates (serial)	asynchronous: 9.6 to 115.2 kbit/s SPI: up to 1 Mbit/s
Direct Application interfaces	Wiegand, OMRON (Clock & Data, ABA), BPA/L
Digital input / output	4 input / 4 output
Operating temperature	-20 °C to 85 °C / -4 °F to 185 °F
Conformity	CE, FCC
Casing	PLCC84 (30.2 x 30.2 x 6.75 mm)
On-chip Application Processor	
Processor	8 bit CPU, M8C core; up to 24 MHz
Memory	32 kByte flash, 2 kByte SRAM, extendable with external EEPROM
Additional System resources	I ² C, multiple SPI, dynamically configurable analog/digital blocks
Programmable analog/digital dynamic interface	18 pin, pre-configured keyboard, LCD, sensor/actuator drivers

Programmable on-chip Application Processor

The built in programmable Application Processor can be enabled as host to manage and process the contactless smart card as well as peripherals and network. The Application Processor includes configurable blocks of analog and digital logic to flexibly connect customized peripheral. The application can be fully integrated. An advanced development tool with a user-friendly GUI, predefined function modules and application libraries in C is available.