



Chip Card & Security ICs

PJM Item Tag / Stack Tag

SRF 66V10 IT

SRF 66V10 ST

Intelligent 10 Kbit EEPROM with Contactless Interface

SRF 66V10 IT complying to ISO/IEC 18000-3 Mode 2

SRF 66V10 ST enhancement of ISO/IEC 18000-3 Mode 2

SRF 66V10 Short Product Information		Ref.: SPI_SRF66V10_1205.doc
Revision History: Current Version 2005-12-20		
Previous Releases: 2005-07-29		
Page	Subjects (changes since last revision)	

Important: Further information is confidential and on request. Please contact:
 Infineon Technologies AG in Munich, Germany,
 Chip Card & Security ICs,
 Tel +49 (0)89 / 234-80000
 Fax +49 (0)89 / 234-81000
 E-Mail: security.chipcard.ics@infineon.com

**Published by Infineon Technologies AG, AIM CC Applications Group
 D-81726 München
 © Infineon Technologies AG 2005
 All Rights Reserved.**

To our valued customers

We constantly strive to improve the quality of all our products and documentation. We have spent an exceptional amount of time to ensure that this document is correct. However, we realise that we may have missed a few things. If you find any information that is missing or appears in error, please use the contact section above to inform us. We appreciate your assistance in making this a better document.

Attention please!

The information herein is given to describe certain components and shall not be considered as warranted characteristics.

Terms of delivery and rights to technical change reserved.

We hereby disclaim any and all warranties, including but not limited to warranties of non-infringement, regarding circuits, descriptions and charts stated herein.

Infineon Technologies is an approved CECC manufacturer.

Information

For further information on technology, delivery terms and conditions and prices please contact your nearest Infineon Technologies Office in Germany or our Infineon Technologies Representatives world-wide (see address list).

Warnings

Due to technical requirements components may contain dangerous substances. For information on the types in question please contact your nearest Infineon Technologies Office.

Infineon Technologies Components may only be used in life-support devices or systems with the express written approval of Infineon Technologies, if a failure of such components can reasonably be expected to cause the failure of that life-support device or system, or to affect the safety or effectiveness of that device or system. Life support devices or systems are intended to be implanted in the human body, or to support and/or maintain and sustain and/or protect human life. If they fail, it is reasonable to assume that the health of the user or other persons may be endangered.

Intelligent 10 Kbit EEPROM with Contactless Interface complying to or an enhancement of ISO/IEC 18000-3 Mode 2

Features

- **10 Kbit EEPROM**
 - Organised in 127 pages located in 1 sector
 - Each page organised in 8 bytes for data storage
 - Service Area 14 bytes
 - User Area 1002 bytes
 - Unique chip identification number
 - Lockable chip memory to prevent overwriting of user or manufacturer selected defined area
- **Optional 48 bit password protection to prevent unauthorised write to memory**
- **High Transaction speed for PJM Tag**
 - Maximum transfer rate of 848 kbps from tags to reader
- **Zero separation of tags for PJM Stack Tag**
 - Tags placed with zero separation can still be identified, read from and written to
- **Physical Interface and Anticollision complying to ISO/IEC 18000-3 Mode 2**
 - Carrier frequency: 13.56 MHz
 - Data transfer rate (to tag): 424 kbps
 - Data transfer rate (from tag): 106 kbps on each of 8 channels
 - Anticollision method complying with ISO/IEC 18000-3 Mode 2 with identification of up to 1200 tags/s
 - Reply channel hopping over 8 channels allows simultaneous communication to 8 tags
 - Can be commanded to mute temporarily to speed up the identification of multiple tags
 - IT tag coupling distance from 0 to 100 cm (influenced by external circuitry i.e. reader-antenna configuration)
- **EEPROM updating (erase and program) time maximum 5 ms per page**
- **EEPROM endurance minimum 10⁵ write/erase cycles¹⁾**
- **Data retention for minimum of 10 years¹⁾**
- **ESD protection typical 6 kV**
- **Ambient temperature –25 ... +70°C**

Development Tool Overview

The Evaluation Kit PJM consists of a desktop reader that comes with a software package. With the kit, 20 PJM Y2.0 samples (dimension of 45 mm x 76 mm), consisting of 10 PJM IT and PJM ST each, are included in the package.

Ordering Info: Evaluation Kit pj, Ordering-No. Q67100-Z3408

¹⁾ Values are temperature dependent

1 Ordering and Packaging information

Table 1 Ordering Information

Type	Package ¹⁾	Remark	Ordering Code
SRF 66V10 IT C	Die (on wafer)	unsawn	on request
SRF 66V10 IT NB	Die (on wafer)	NiAu-Bump, sawn	on request
SRF 66V10 ST C	Die (on wafer)	unsawn	on request
SRF 66V10 ST NB	Die (on wafer)	NiAu-Bump, sawn	on request

Pin Description

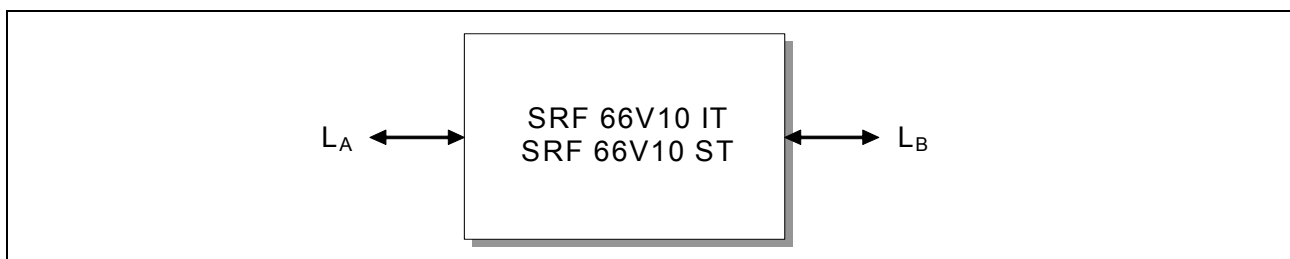

Figure 1 Pad Configuration Die

Table 2 Pin Definitions and Functions

Symbol	Function
L _A (AC1)	Antenna connection
L _B (AC2)	Antenna connection

¹⁾ Available as NiAu-bump version (NB) or as a die on unsawn wafer (C) for customer packaging

2 PJM products for High Speed & universal RFID-applications and High density & closely stacked RFID-applications

PJM products are designed to meet the increased demands of both speed and stacking capability for a broad range of applications. In addition to the features available in ISO 15693 products, this family of contactless memories offers unique features (higher speed and stacking) that would be able to address existing and new contactless applications.

PJM products focus on higher transaction speed (IT and ST) and zero separation (ST). With IT and ST, the maximum transaction speed available is 848 kbps with the chips replying over 8 channels to a reader with a corresponding number of channels.

Applications are supported very flexibly with the features of PJM IT and ST. An optional 48bit password protection prevents unauthorized write access to the memory area. A locking mechanism is available to prevent overwriting of user and manufacturer memory areas. With a command rate of 424 kbps and reply rate of 106 kbps, the throughput is much higher than the 26 kbps offered by ISO 15693 products. In addition, with the ability to reply on 8 channels, the productivity of contactless system is increased many times.

The ST offers the unique stacking feature which permits items to be stacked together while still being able to be read and written to. The stacking capability addresses contactless application where zero separation of items is unavoidable or likely to happen. A credit card sized inlay with 2½ turns can easily be stacked to more than 100 tags.

PJM products are available in 2 versions: Item Tag (IT) and Stack Tag (ST). Both versions come with a memory size of 10 Kbit, with 8128 bit user accessible area.

All PJM products comply with or are an enhancement of ISO/IEC 18000 Part 3 Mode 2. The power supply and data are transferred to PJM products via an antenna. IT PJM products are designed to communicate up to a typical distance of 100 cm with a contactless reader in an appropriate gate configuration.

2.1 Circuit Description

The PJM chip circuit consists of an EEPROM memory unit, an analog interface for contactless energy, a PJM Demodulator and control units.

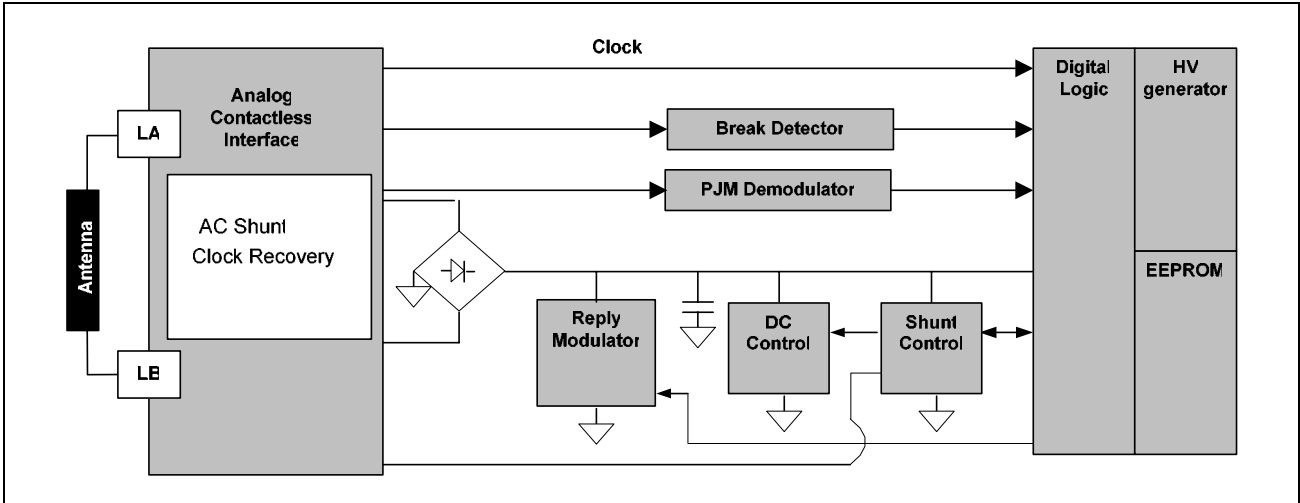

Figure 2 Block diagram of PJM chip circuit

2.2 System Overview

The system consists of a contactless label on one hand and a contactless reader together with an antenna on the other.

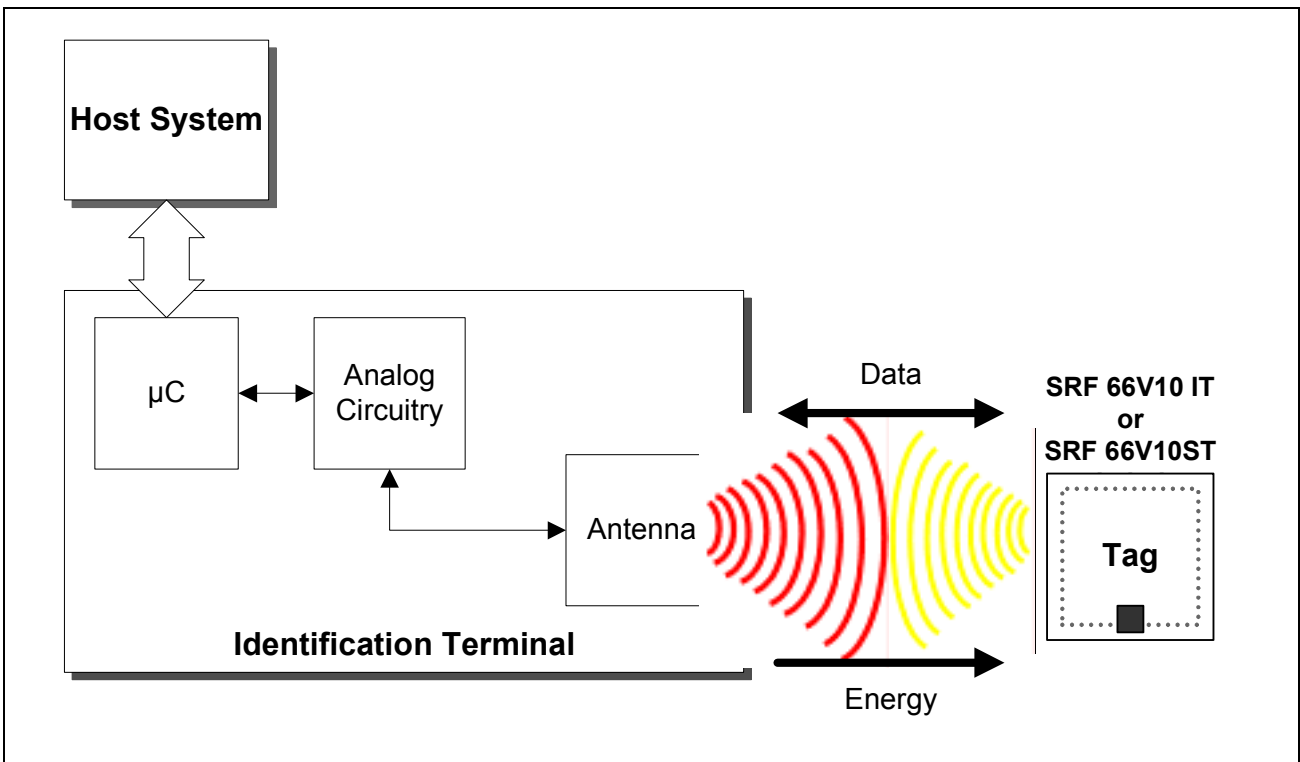

Figure 3 Contactless System Example

Contactless Energy and Data Transfer

The operating distance between IT label and reader antenna is typically up to 100 cm in an appropriate gate configuration. The label antenna consists of a simple coil with a few turns. Contactless labels are passive. The RF communication interface allows to exchange data with 424/106 kbit/s (downlink/uplink). This high data transmission rate permits short transaction times.

An intelligent anticollision function allows operation with more than one label in the field simultaneously. The anticollision algorithm selects each label individually and ensures that the execution of a transaction with a selected label is performed correctly without data corruption resulting in other labels.

System Security

The serial number is unique for each label and can not be changed.