

HF Reader System Series 6000
S6700 Multi Protocol Transceiver IC
RI-R6C-001A

Reference Guide



Edition Four– July 2005

This is the fourth edition of this manual. It describes the following product:

S6700 Multi Protocol Transceiver IC RI-R6C-001A-03

Important Notice

Texas Instruments (TI) reserves the right to make changes to its products or services or to discontinue any product or service at any time without notice. TI provides customer assistance in various technical areas, but does not have full access to data concerning the use and applications of customer's products.

Therefore, TI assumes no liability and is not responsible for customer applications or product or software design or performance relating to systems or applications incorporating TI products. In addition, TI assumes no liability and is not responsible for infringement of patents and/or any other intellectual or industrial property rights of third parties, which may result from assistance provided by TI.

TI products are not designed, intended, authorized or warranted to be suitable for life support applications or any other life critical applications which could involve potential risk of death, personal injury or severe property or environmental damage.

The **TIRIS** and **TI-RFid** logos, and the words **TIRIS**, **TI-RFid** and **Tag-it** are trademarks or registered trademarks of Texas Instruments Incorporated.

Copyright © 2005 Texas Instruments Incorporated (TI)

This document may be downloaded onto a computer, stored and duplicated as necessary to support the use of the related TI product. Any other type of duplication, circulation or storage on data carriers in any manner not authorized by TI represents a violation of the applicable copyright laws and shall be prosecuted.

About This Guide

This reference guide for the S6700 Multi Protocol Transceiver IC is designed for use by TI partners who are engineers experienced with Radio Frequency Identification Devices (RFID).

Regulatory, safety and warranty notices that must be followed are given in Chapter 5.

Conventions



WARNING:

A WARNING IS USED WHERE CARE MUST BE TAKEN OR A CERTAIN PROCEDURE MUST BE FOLLOWED, IN ORDER TO PREVENT INJURY OR HARM TO YOUR HEALTH.



CAUTION:

This indicates information on conditions which must be met, or a procedure which must be followed, which if not heeded could cause permanent damage to the equipment or software.



Note:

Indicates conditions which must be met, or procedures which must be followed, to ensure proper functioning of the equipment or software.



Information:

Indicates information which makes usage of the equipment or software easier.

If You Need Assistance

For more information, please contact the sales office or distributor nearest you. This contact information can be found on our web site at:

<http://www.ti-rfid.com>.

Document Overview

Chapter 1: Introduction	7
1.1 General.....	8
1.2 System Description.....	8
1.3 Product Description	8
1.4 Communications Protocols.....	9
1.5 Delivery.....	9
Chapter 2: Transceiver IC Description	11
2.1 Functional Description	12
2.1.1 Power Supply	12
2.1.2 Transmitter	13
2.1.3. Receiver	13
2.1.4 Reference Clock and Internal Oscillator	13
2.1.5 Rest Defaults and Power Management	13
2.1.6 Serial Communication Interface	14
2.2 Pin Description	14
Chapter 3: Technical Data	16
3.1 Specification Summary.....	16
3.2 Mechanical Information	20
Chapter 4: Protocol Definition	22
4.1 General Remarks and Basic Command Structure.....	23
4.1.1 Definition of Start (S1), Stop (ES1) and Data Bit	24
4.1.2 Command Byte Definition	25
4.1.3 Transmitter Off Command.....	26
4.1.4 Transmitter On Command.....	27
4.2 Operating Modes	27
4.2.1 Common Points (Normal and Register Mode)	27
4.2.2 Normal Mode.....	27
4.2.3 Register Mode	28
4.3 RF Protocol.....	29
4.3.1 General.....	29
4.3.2 Direct Mode	30
4.4 Register Configuration.....	31
4.4.1 Write Data to Configuration Register	31
4.4.2 Read Data to Configuration Register	31
4.5 Communication.....	32
4.5.1 FIFO Management	32
4.5.2 Basic Request / Response	33
4.5.3 Bi-directional SCLOCK.....	35
4.5.4 Simultaneous Identification (SID) / Anti-collision	36
4.6 Power Management	37
4.6.1 Idle Mode.....	37
4.6.2 Power Down Mode	37
4.7 Pin M_ERR.....	37

Chapter 5: Regulatory, Safety and Warranty Notices	38
5.1 Regulatory, Safety and Warranty Notices	39
5.2 Warranty and Liability	39
APPENDIX A: Application Examples	40
APPENDIX B: Command Byte Overview	43
APPENDIX C: Register Definition	45
APPENDIX D: Terms & Abbreviations	48

List of Figures

Figure 1 S6700 Multi Protocol Transceiver IC (RI-R6C-001A)	8
Figure 2 Tape Dimensions	9
Figure 3 Reel Dimensions	10
Figure 4 Simplified Block Diagram	12
Figure 5 Transceiver Pins	14
Figure 6 Transceiver IC Sending Data	19
Figure 7 Mechanical Construction	20
Figure 8 Command Structure	23
Figure 9 Definitions	24
Figure 10 Shut Down Command	26
Figure 11 Normal Mode	28
Figure 12 Register Mode	28
Figure 13 Direct Mode	30
Figure 14 Write Configuration Register	31
Figure 15 Read from Configuration Register	31
Figure 16 FIFO Management	32
Figure 17 Basic Request / Response	34
Figure 18 Bi-directional SCLOCK	35
Figure 19 Simultaneous Identification (SID) / Anti-collision	36
Figure 20 Application Circuit	40

List of Tables

Table 1 List of Connectors	15
Table 2 General Parameters	17
Table 3 Specifications	17
Table 4 Meaning of Symbols in Figure 7	21
Table 5 Command Byte Definition	25
Table 6 Meaning of Bits 4, 5 & 6	25
Table 7 Configuration Commands	26
Table 8 Overview of #Bits present in FIFO	33
Table 9 Part List for Application Circuit	41
Table 10 Modulation Resistor Values	42

Introduction

This chapter introduces you to the S6700 Multi Protocol Transceiver IC.

Topic	Page
1.1 General	8
1.2 System Description	8
1.3 Product Description	8
1.4 Communications Protocols.....	9
1.5 Delivery	9

1.1 General

This document provides information about the S6700 Multi Protocol Transceiver IC. It describes the integrated circuit and how to implement it.

1.2 System Description

The HF Reader System Series 6000 works at a frequency of 13.56 MHz. It comprises a reader, antenna and transponder (for example: smart label) and is used for wireless identification.

The system works according the “reader talks first” principle which means that the transponder keeps quiet until the reader sends a request to it. The reader can rapidly and simultaneously identify numerous transponders in the antenna’s field. It can write data to and read data from the transponders; either in addressed mode by using the factory programmed read only number, or in general mode to all of the transponders in its field. The read/write capability of the transponder allows users to update the data stored in the transponders memory anywhere along its movements.

1.3 Product Description

The S6700 Multi Protocol Transceiver IC opens a rapid path for the development of a broad range of 13.56 MHz RFID readers. It provides the receive/transmit functions required to communicate with a variety of transponders that operate in the 13.56 MHz ISM band. A transmit encoder converts the transmitted data stream into the selected protocol; protocol selection is done in the header of the transmitted data string. The transmitter can provide up to 200 mW of RF power to a matched 50 Ω load with a 5 V power supply. Higher output power can be obtained by an external amplifier.

The receive decoder converts the signals from the RF receiver into a simple data string.

The digital interface provides on-chip data encoding and recovery, thereby minimizing the software design efforts for the end user. Communication with the circuit is achieved by means of a three wire serial link.

Figure 1 S6700 Multi Protocol Transceiver IC (RI-R6C-001A)

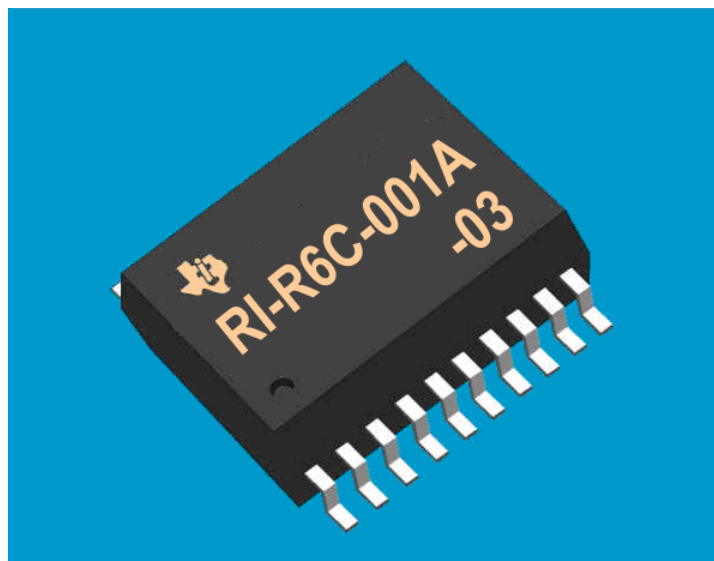

1.4 Communications Protocols

The Transceiver IC can handle different RF protocols as follows:

Tag-it protocol.

ISO / IEC 15693-2 [2].

ISO / IEC 14443-2 (Type A).

Direct mode where data can be passed directly thru to a transponder; using the correct modulation, timing, and command structure.

1.5 Delivery

The Transceiver IC is available in an SSOP20 plastic package and will be delivered in quantities of 1500 units packed tape-on-reel. The dimensions for the carrier tape and reel are shown on Figure 2 and Figure 3.

Figure 2 Tape Dimensions

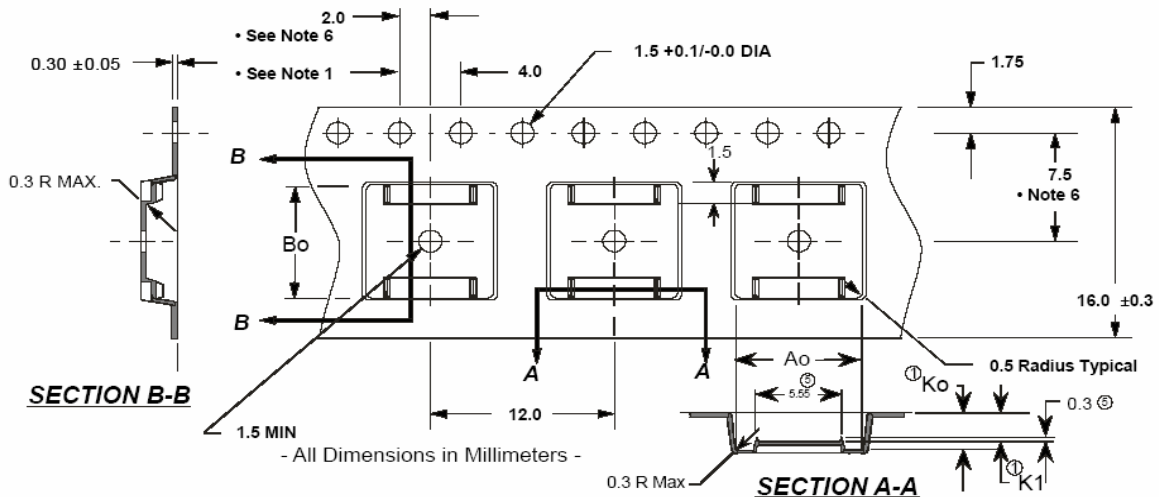

$A_0 = 8.2$	$K_1 = 2.3$	$K_0 = 3.0$	$B_0 = 7.6$
-------------	-------------	-------------	-------------



Notes:

- 1) 10 sprocket hole pitch cumulative tolerance ± 0.2 mm.
- 2) Camber not to exceed 1 mm in 100 mm.
- 3) Material: Black Conductive Polystyrene.
- 4) A_0 and B_0 measured on a plane 0.3 mm above the bottom of the pocket.
- 5) K_0 measured from a plane on the inside bottom of the pocket to the top surface of the carrier.
- 6) Pocket position relative to sprocket hole measured as true position of pocket, not pocket hole.

Figure 3 Reel Dimensions

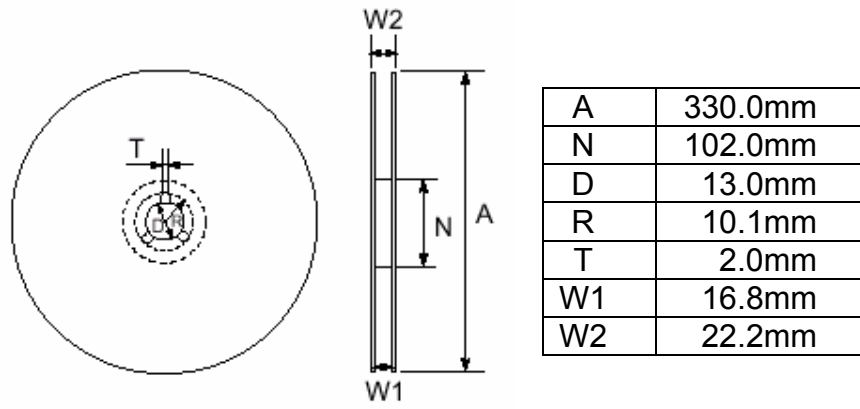

Transceiver IC Description

This chapter describes the hardware of the S6700 Transceiver IC. It describes the transceiver's functionality and its interfaces.

Topic	Page
2.1 Functional Description	12
2.1.1 Power Supply	12
2.1.2 Transmitter	13
2.1.3. Receiver.....	13
2.1.4 Reference Clock and Internal Oscillator.....	13
2.1.5 Rest Defaults and Power Management.....	13
2.1.6 Serial Communication Interface	14
2.2 Pin Description	14

2.1 Functional Description

A simplified block diagram of the Transceiver IC is shown in Figure 4, the different electronic parts of the IC are described in sections 2.1.1 to 2.1.6.

Figure 4 Simplified Block Diagram

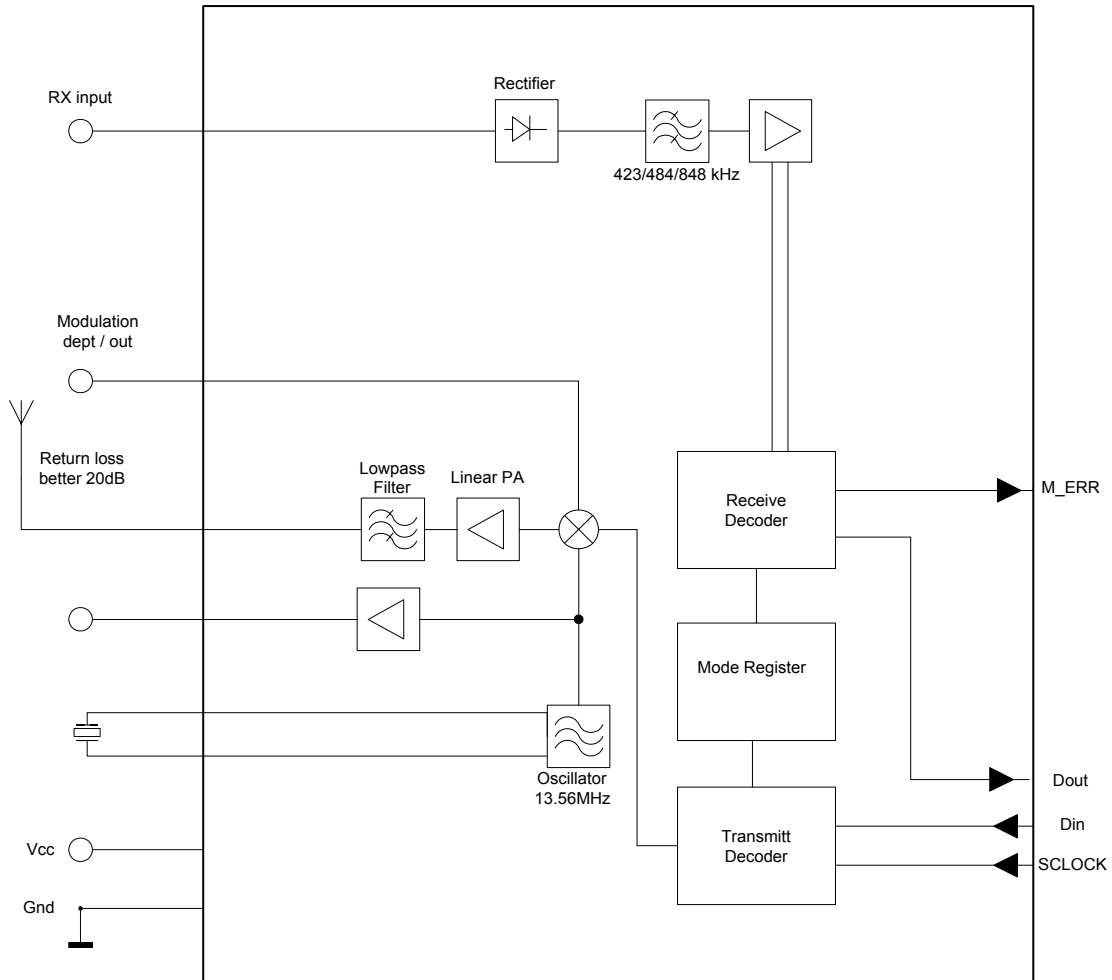

2.1.1 Power Supply

The Transceiver IC requires a nominal 5 volts external power supply. Operation is guaranteed between 3 Volts and 5.5 Volts. The current drain depends on the antenna impedance and the output matching network configuration. We strongly recommended that you use a well regulated supply as power supply ripple and noise will severely degrade the overall system performance.

2.1.2 Transmitter

The output transistor is a low R_{ds} on MOSFET. The drain is directly accessible on the TX_OUT pin. A recommended application schematic optimized to drive a resistive fifty ohms antenna with a five volts power supply is shown in Appendix A. A simple resonant circuit or/and a simple matching network can be connected to the output to reduce harmonic suppression and enhance the general performance.

100% modulation is achieved by means of gating the square wave drive of the output transistor.

The ten percent modulation depth is obtained by means of switching a resistor in series with the output transistor source connection. Increasing the value of this resistor further increases the modulation depth.

The transmit encoder converts the data into the selected RF Protocol to be transferred. The communications speed varies from 5 to 120 kbaud and must be at least the speed of the selected transponder protocol. An input buffer is implemented in order to have a sufficient number of bits available for the RF transmission.

2.1.3. Receiver

The receiver input is typically connected to the antenna through an external resistor. The modulation from the tag is then recovered by means of a diode envelope detector.

The receiver decoder issues the received data directly to the controller in binary data format. The communication speed and RF protocol is defined by the selected mode. Start, stop and errors in the received data string are detected and indicated at the output.

2.1.4 Reference Clock and Internal Oscillator

The reference clock can be obtained externally by applying a suitable clock signal to the XTAL2 pin. A sine wave centered at $V_{CC}/2$ or a CMOS logic compatible signal is an acceptable external system clock. The built-in reference oscillator will work either with a quartz crystal or a ceramic resonator. The nominal system clock frequency is 13.56 MHz, but the oscillator will work at any frequency from 4 MHz to 16 MHz. A buffered version of the crystal oscillator signal is available for synchronization purposes on pin 8 (XTAL_CLOCK).

2.1.5 Rest Defaults and Power Management

After a power on reset has been performed, the device is placed in its default configuration. There are three available power modes. In the first mode, the device is fully powered. In the idle mode, only the reference oscillator and a minimal set of associated circuitry are running. In the power down mode, the device internal bias system is completely switched off. The circuit is woken by applying a rising edge on the DIN line while SCLOCK is held high.

2.1.6 Serial Communication Interface

The communication interface normally uses three wires:

SCLOCK, serial clock, bi-directional.

DIN, data input, as seen by the circuit

DOUT, data output, as seen by the circuit

The commands are sent with the most significant bit (MSB) in the first position. All signals are internally synchronized with the system clock.

The bit protocol is fully described in Chapter 4.

2.2 Pin Description

Figure 5 shows the Transceiver IC and the signals on each pin. They are further described in Table 1.

Figure 5 Transceiver Pins

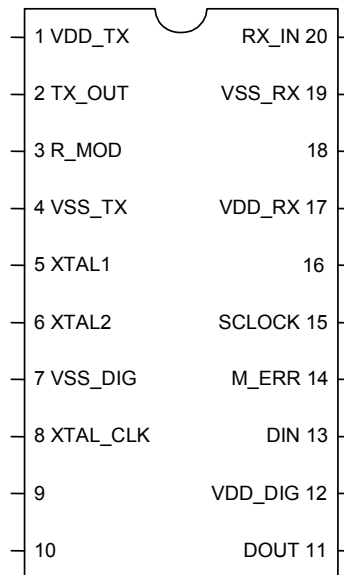

Table 1 List of Connectors

Pin Number	Signal Name	Description
1	VDD_TX	Transmitter power supply
2	TX_OUT	Output transistor drain connection
3	R_MOD	External resistor to set 10% modulation depth mode
4	VSS_TX	Transmitter section ground
5	XTAL1	Pin 1 of Xtal resonator
6	XTAL2	Pin 2 of Xtal resonator and external system clock input
7	VSS_DIG	Digital section ground
8	XTAL_CLK	Buffered output of Xtal oscillator
9	not used	Grounded for normal operation
10	not used	Grounded for normal operation
11	DOUT	Data output for serial link
12	VDD_DIG	Digital section power supply
13	DIN	Data input for serial link
14	M_ERR	Manchester Protocol error flag
15	SCLOCK	Serial link clock
16	not used	Leave open for normal operation
17	VDD_RX	Receiver section power supply
18	not used	Leave open for normal operation
19	VSS_RX	Receiver section ground
20	RX_IN	Receiver input

Technical Data

This chapter provides the technical specifications of the S6700 Transceiver IC. It also provides information about packing and storage.

Topic	Page
3.1 Specification Summary.....	17
3.2 Mechanical Information.....	20

3.1 Specification Summary

These specifications apply under the following environmental conditions unless otherwise stated:

Ambient temperature = -40 °C to +85 °C,

Input voltage = 5 Volts,

The on-board resonator was used.

Table 2 General Parameters

Parameter	Condition	Min	Typ	Max	Unit
Interface	Serial Interface, CMOS compatible				
Package	SSOP20				
Mold compound	EME6600H				
Lead frame material	CDA C19400				
Lead finish material	Pure Sn plating				
Operating temperature		-40		+85	°C
Storage temperature		-55		+125	°C
Power dissipation				500	mW
ESD protection	MIL-STD-883, Method 3015 (2kV, 1.5 kW, 100 pF)				
Soldering conditions	IPC/JEDEC J-STD-020C				
Storage conditions	MSL Level 3, IPC/JEDEC J-STD-033A				
Lead-Free	Yes, according to RoHS*				

* **Pb-Free (RoHS):** TI-RFID's terms "Lead-Free" or "Pb-Free" mean TI-RFID products that are compatible with the current RoHS requirements for all 6 substances, including the requirement that lead not exceed 0.1% by weight in homogeneous materials. Where designed to be soldered at high temperatures, TI Pb-Free products are suitable for use in specified lead-free processes.

Table 3 Specifications

Parameter	Condition	Min	Typ	Max	Unit
General DC Parameters:					
Supply voltage (Vdd)	Vdd with respect to Vss	3	5	5.5	Volt
Supply ripple	See note 3			40	mVpp
Stand-by current consumption (Istb)	Vdd=5.5 V	-	1	50	µA
Idle mode current consumption (Idle1) (Analog section off)	External clock Vdd=5.5 V	-	12	15	mA
Idle mode current consumption (Idle2) (Analog section off)	On board resonator Vdd=5.5 V	3	7	11	mA
Operating current (Iop)	-	9	14	19	mA
Transmit current (Itr)	See note 1	80	100	120	mA

Parameter	Condition	Min	Typ	Max	Unit
Transmitter specifications:					
Max peak voltage applied on drain of output transistor	-	-	-	32	V
Max output transistor power dissipation	-	-	-	500	mW
Output transistor ON resistance	I _d = 50 mA	-	2	5	Ohm
Output power for five volts operation	See note 1	180	200	-	mW
Amplitude modulation depth adjustment range in 10% mode, with external resistor connected between R_MOD pin and ground.	See note 1	0%	-	90%	-
Amplitude modulation depth in 10% mode with 12 Ohm external resistor	See note 1	10%	12%	16%	-
Minimum depth for 100% ASK	See note 1	40	-	-	dB
Rise and fall time for 100% ASK	See note 1	-	2.5	4	µs
Rise and fall time for 10% modulation depth (nominal external resistor used)	See note 1	-	1	1.5	µs
Receiver specifications:					
Input RF voltage range (RX_IN - VSS)	With 1 k series external resistor	1	1.8 - 4.9	V _{dd}	Volt
Receiver sensitivity (FSK)	See note 1	-40	-65	-	dBm
Baseband receiver sensitivity (FSK)	See note 1	-40	-65	-	dBm
FSK IF filter cut off points		130	200-1400	1800	kHz
Total gain, in FSK mode	-	100	120	140	dB
Log amplifier section:					
Limiting gain	-	70	80	-	dB
Sensitivity for AM recovery	-	-40	-55	-	dBm
Sensitivity for FM recovery	-	-40	-65	-	dBm
Serial Link and digital I/O:					
Output voltage low (Vol)	I _{max} =1mA	0	0.2	0.4	Volt
Output voltage high (Voh)		4.6	4.8	5	Volt
Output current drive (Iol)	V _{ol} ≤ 0.4 Volt	1	-	-	mA
Input voltage high (Vih)		0.7 V _{dd}	-	V _{dd} + 0.3	V
Input voltage low (Vil)		-0.3	-	0.3 V _{dd}	V
SCLOCK frequency	See note 4			1.5	MHz
SCLOCK and DATA set up time	See Figure 6		300		Ns

Parameter	Condition	Min	Typ	Max	Unit
Xtal Oscillator:					
Frequency range (Fxtal)	-	4	13.56	16	MHz
Start-up time (Tstart)	-	-	2	5	Ms
Xtal series resistance			50	100	Ohm
External clock signal specifications: See note 2					
Min sine wave amplitude AC coupled	-	1	-	Vdd	Volt pp
Min sine wave amplitude, DC coupled	has to be centered around Vdd/2	1	-	Vdd	Volt pp
XTAL_CLK output specifications:					
XTAL_CLK Low Level (Col)	1K load resistor	0	0.2	0.4	Volt
XTAL_CLK High Level (Coh)	1K load resistor	4.6	4.8	5.0	Volt
Rise and fall times (10%-90%)	1K load resistor 12pF load capacitance	-	3	-	ns



Notes:

- 1) This parameter is specified with the IC wired as shown in the typical application circuit shown in Appendix A, with the transmitter switched on.
- 2) The external clock symmetry is of paramount importance. It has a direct influence on the transmitter output power. When using a sine wave as an external clock input, it must not show visible distortion. If a square wave is used, its duty cycle has to be equal to 50%. In all cases, the resulting duty cycle should be checked on the XTAL_CLK pin when it is configured as an output.
- 3) The maximum ripple current could result in a 10% reduction of the reading distance.
- 4) The minimum frequency must be high enough that the Transceiver IC always has data available to send.

Figure 6 Transceiver IC Sending Data

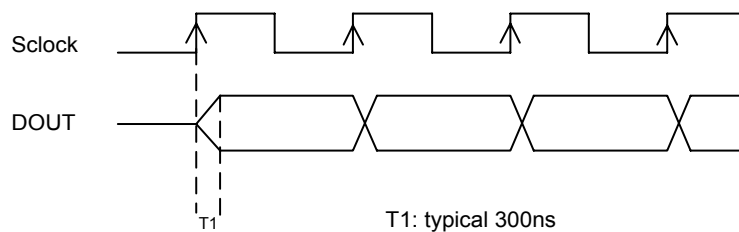

3.2 Mechanical Information

Figure 7 Mechanical Construction

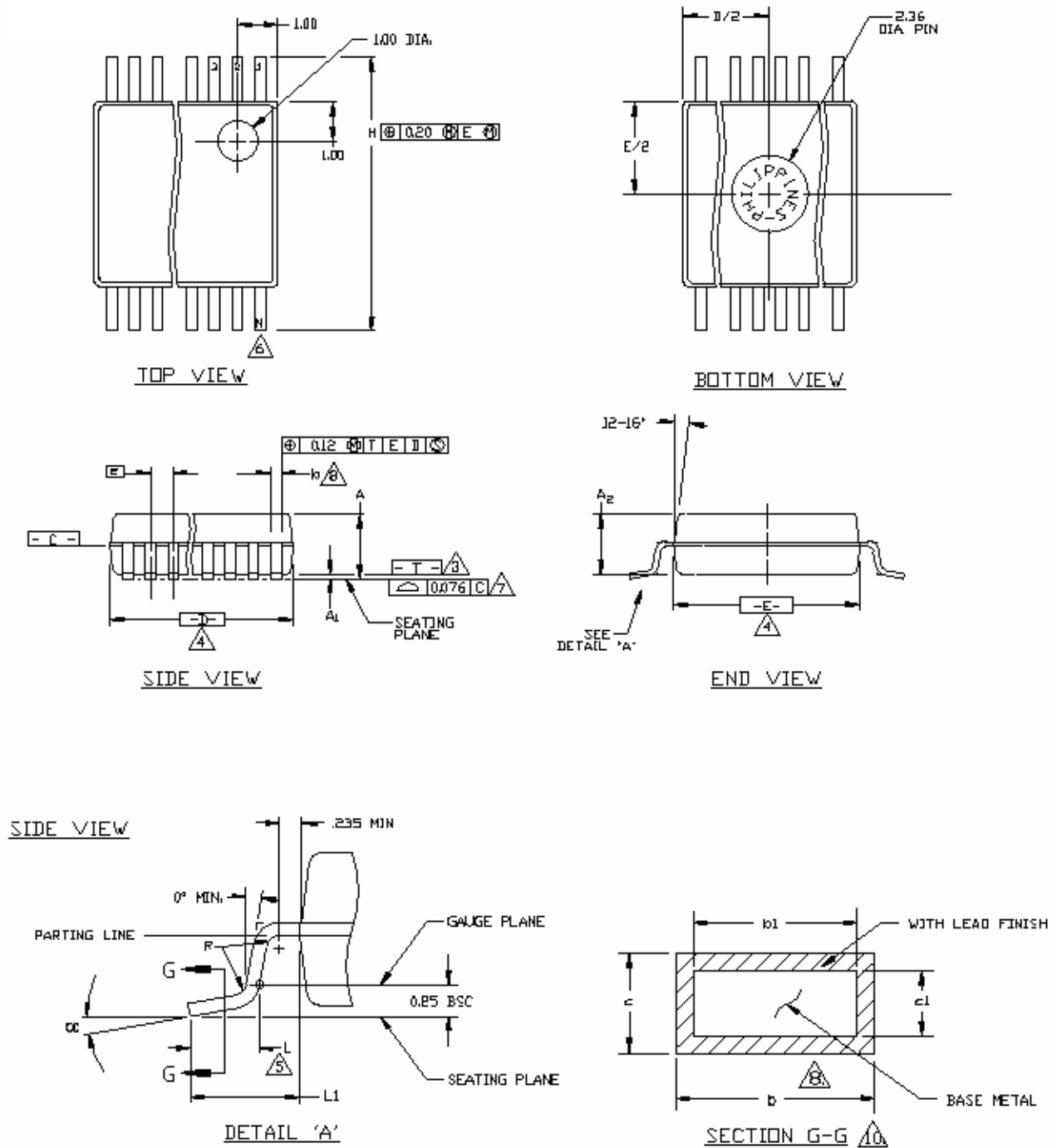

See Table 4 on next page for details of the symbols in Figure 7.

Table 4 Meaning of Symbols in Figure 7

Symbol	Min.	Nom.	Max.	See Note
A	1.73	1.86	1.99	
A1	0.05	0.13	0.21	
A2	1.68	1.73	1.78	
b	0.25	-	0.38	8, 10
b1	0.25	0.30	0.33	10
c	0.09	-	0.20	10
c1	0.09	0.15	0.16	10
D	7.07	7.20	7.33	4
E	5.20	5.30	5.38	4
E	0.65BSC			
H	7.65	7.80	7.90	
L	0.63	0.75	0.95	5
L1	1.25 Ref.			
N	20			
A	0°	4°	8°	
R	0.09	0.15		

**Notes:**

- 1) This package outline drawing complies with JEDEC Specification No. MO-150.
- 2) Dimensions and Tolerances per ANSI.Y14.5M-1982.
- 3) "T" is a reference datum.
- 4) "D" & "E" are reference datums and do not include mold flash or protrusions, but do include mold mismatch and are measured at the parting line. Mold flash or protrusions shall not exceed 0.15 mm per side.
- 5) Dimension is the length of terminal for soldering to a substrate.
- 6) Terminal positions are shown for reference only.
- 7) Formed leads shall be planar with respect to one another within 0.08 mm at seating plane.
- 8) Dimension b does not include dambar protrusion/intrusion. Allowable dambar protrusion shall be 0.13 mm total in excess of b dimension at maximum material condition. Dambar intrusion shall not reduce dimension b by more than 0.07 mm at least material condition.
- 9) Controlling dimension: millimeters.
- 10) These dimensions apply to the flat section of the lead between 0.10 mm and 0.25 mm from lead tips.

Protocol Definition

This chapter provides information about the communication protocol used by the S6700 Transceiver IC.

Topic	Page
4.1 General Remarks and Basic Command Structure	23
4.1.1 Definition of Start (S1), Stop (ES1) and Data Bit	24
4.1.2 Command Byte Definition	25
4.1.3 Transmitter Off Command	26
4.1.4 Transmitter On Command	27
4.2 Operating Modes	27
4.2.1 Common Points (Normal and Register Mode)	27
4.2.3 Register Mode	27
4.3 RF Protocol	29
4.3.1 General	29
4.3.2 Direct Mode	30
4.4 Register Configuration	31
4.4.1 Write Data to Configuration Register	31
4.4.2 Read Data to Configuration Register	31
4.5 Communication	32
4.5.1 FIFO Management	32
4.5.2 Basic Request / Response	33
4.5.2.1 Definition TRAN1	34
4.5.2.2 Definition TRAN2	34
4.5.3 Bi-directional SCLOCK	35
4.5.4 Simultaneous Identification (SID) / Anti-collision	36
4.6 Power Management	37
4.6.1 Idle Mode	37
4.6.2 Power Down Mode	37
4.7 Pin M_ERR	37

4.1 General Remarks and Basic Command Structure

The protocol uses a simple three wire serial link between the Transceiver IC and a remote controller (microprocessor) to transmit data and set up data. All signals travelling on this interface must be resynchronised and debounced. It is important to allow a 70 ns debounce time before looking for any signal change. For example, if SCLOCK rises 70 ns before DIN the Transceiver IC serial interface may see them as rising together.

For each communication, the remote controller must send a command to perform an appropriate sequence. A typical command is structured as follows: (S1, eight bits command, data, ES1). More actions may follow a specific command but sending S1 will in general initiate a new sequence.

A sequence is defined as being all signals between the first S1 (that belongs to the sequence) and the next S1 (that belongs to the next sequence).

		Size/length	
S1	Start	1 Bit	
Command	Command byte	8 Bits	
Bin. Data	Binary data	X Bits	depending on message
ES1	Stop	1 Bit	

Figure 8 Command Structure

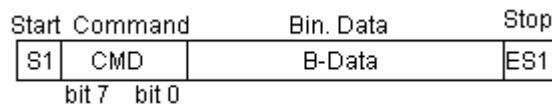

Note:



You should switch the transmitter on (as described in section 4.1.4) before you send the first command, otherwise it could happen that the first command is not correctly performed.

4.1.1 Definition of Start (S1), Stop (ES1) and Data Bit

Start, stop, and data are indicated by the sequences:

- Start (S1) is defined as the start of the communication sequence between the Transceiver IC and the micro-controller. It is a low-to-high transition on the DIN line while SCLOCK is held high.
- Stop (ES1) is defined as the end of the communication sequence and is a high-to-low transition on the DIN line while SCLOCK is held high.
- Each data bit is latched by the rising edge of SCLOCK. The value of the data bit must be settled and has to remain the same while SCLOCK is high.
- The data on DIN can be changed while SCLOCK is low.

Figure 9 Definitions

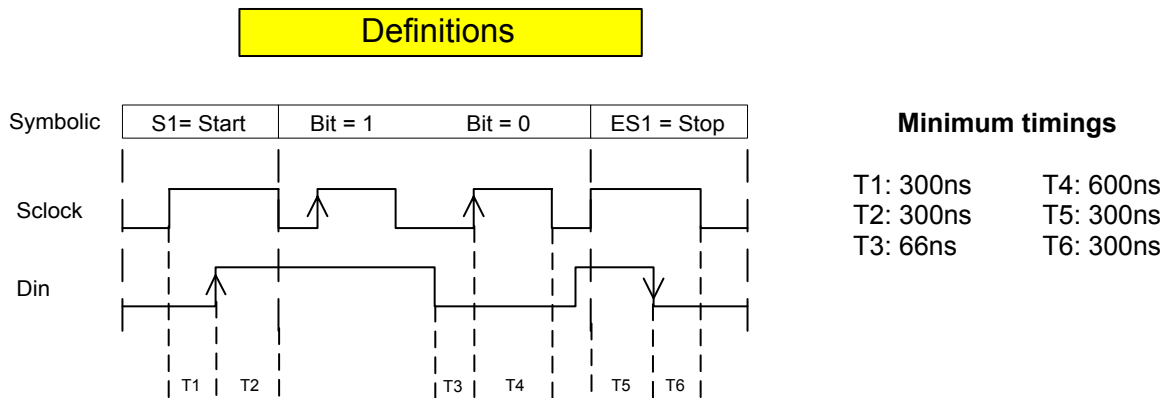

4.1.2 Command Byte Definition

The command byte is defined in Table 5.

Table 5 Command Byte Definition

Bit No.	Description	Function in High Level	Function in Low Level.
7	Mode bit	1 = Register Mode	0 = Normal Mode
6	Table 6	Mode is selected according to Table 6 ISO 15693 (1out of 4) is the default register setting	
5	Table 6		
4	Table 6		
3	Modulation Depth	1 = 100%	0 = 10%
2	AM / FSK	1 = AM selected	0 = FSK selected
1	Baud rate	1 = High Baud rate according to ISO 15693	0 = Low Baud rate according to ISO 15693
0	Parity of first byte	Even parity	

Table 6 Meaning of Bits 4, 5 & 6

Bit # 6	Bit # 5	Bit # 4	Definition
0	0	0	Direct Mode
0	0	1	Tag-it protocol
0	1	0	ISO 15693 / down link 1 out of 4
0	1	1	ISO 15693 / down link 1 out of 256
1	0	0	ISO 14443 Mode A
1	0	1	Reserved
1	1	0	Reserved
1	1	1	Configuration commands Table 7

The configuration commands are used to communicate with the Transceiver IC according to Table 7 below.

Table 7 Configuration Commands

Bit # 7	Bit # 6	Bit # 5	Bit # 4	Bit # 3	Bit # 2	Bit # 1	Bit # 0	Definition
0	1	1	1	0	0	0	1	Read from Configuration Register
0	1	1	1	1	1	0	1	Write to Configuration Register
0	1	1	1	1	1	1	0	Power down



Note:

An overview of supported Command Bytes is given in Appendix B.

4.1.3 Transmitter Off Command

Figure 10 shows a special and fast command to shut down the carrier. This can be constructed with an S1 sequence followed by an ES1 sequence. Therefore, this has been written 'S1' and 'ES1' in the symbolic representation.

The transmitter is kept 'ON' after a RF command was initiated. To switch the transmitter OFF the following sequence is used:

- A transition of SCLOCK from low -to-high.
- A low -to-high transition followed by a high-to-low transition on the Din line while SCLOCK is held high the whole time.
- A transition of SCLOCK from high to low.

Figure 10 Shut Down Command

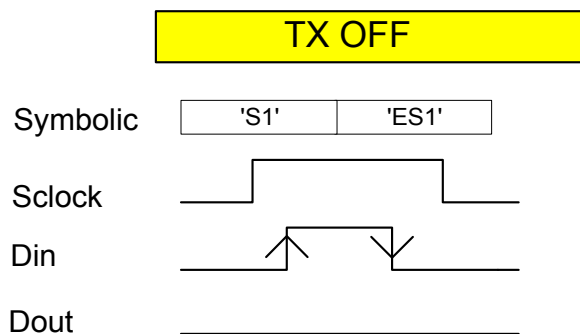

The width of the pulse of Din must be at least 1.2 μs in order to secure the system, and avoid any confusion between a TXOFF command and an S1 command, in case any spurious spike(s) are present on the serial link.

It is not necessary to switch off the transmitter before sending another command and data stream to the Transceiver IC.

4.1.4 Transmitter On Command

The transmitter can be switched on with each of the RF commands in Table 5 except for the configuration commands. The fastest command to switch the transmitter on is a register mode command without data, using the sequence: S1, 1, ES1.

4.2 Operating Modes

There are two operating modes available: normal mode and register mode.

4.2.1 Common Points (Normal and Register Mode)

Following the S1 bit and the command (either normal or register mode), the rest of the sequence is the same.

The number of data bits is arbitrary. The controller sends ES1 when all data bits have been sent. It is the responsibility of the controller to check that the number of data bits is consistent. For example, sending 7 data bits in mode 1out 256 is not consistent. The controller will have no feedback on this error, wrong data or no data at all could be sent. The various CRC sent by the TAG should allow the controller to understand its mistake and, if necessary, to reinitiate a sequence.

The first bit ES1 will probably not finish the sequence since an answer from the TAG will probably be expected. This is explained in figures 12, 14 and 15.

Note that S1 starts the sequence but does not physically modulate the carrier with a SOF. The SOF will be generated by the Transceiver IC itself before sending data. This SOF may depend on the mode. It may only be sent after several data bits have been received by the Transceiver IC. For example, the SOF may be modulated only when 8 bits have been received in the mode 1 out 256. This behaviour is similar in the mode 1 out of 4.

4.2.2 Normal Mode

Figure 11 represents the "Normal Mode". The user sends some configuration inside the command (definition see Table 5) and starts sending data that will be transmitted by the way of modulating the carrier. SOF, data, EOF will be sent to the TAG. There is no timing correlation between the data in the serial interface and the timing of the data transmitted to the TAG. This is the reason why a buffer (FIFO) has been implemented in the Transceiver IC. The signals related to the FIFO will be described in FIFO management section 4.5.2.

Figure 11 Normal Mode

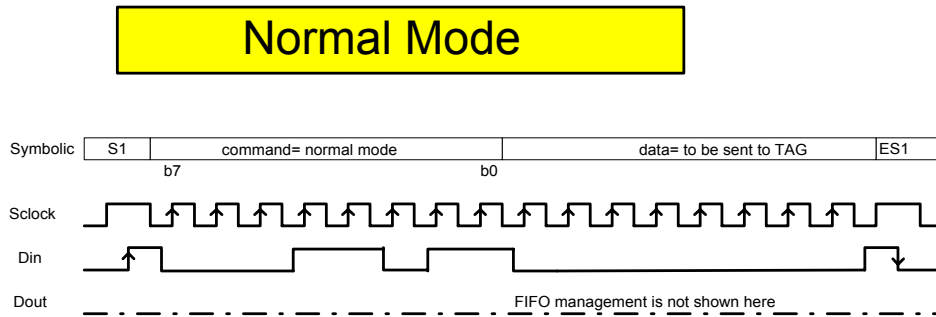

Example:

The data stream to address the Tag-it RF protocol is defined by the following sequence:

- Size/length
- Start (S1) 1 Bit
- Command byte
 - Bit #7 = L, Normal Mode
 - Bit #6 = L, Tag-it protocol
 - Bit #5 = L, “
 - Bit #4 = H, “
 - Bit #3 = H, 100% modulation
 - Bit #2 = L, FM demodulator
 - Bit #1 = H, this field is not applicable, it is set to default
 - Bit #0 = H, even parity
- Data to the tag: Binary data are converted into the Tag-it RF-protocol
- Stop (ES1) 1 Bit

4.2.3 Register Mode

Figure 12 represents the “Register Mode” command. This command is only one bit long and not 8 bits long like all other commands.

In “Register Mode”, the configuration used is the one that has been previously programmed in the Transceiver IC. This configuration should be written using “Write to Configuration Register” (Figure 14) during a previous communication with the Transceiver IC.

The Configuration Register definition is shown in Appendix C.

Figure 12 Register Mode

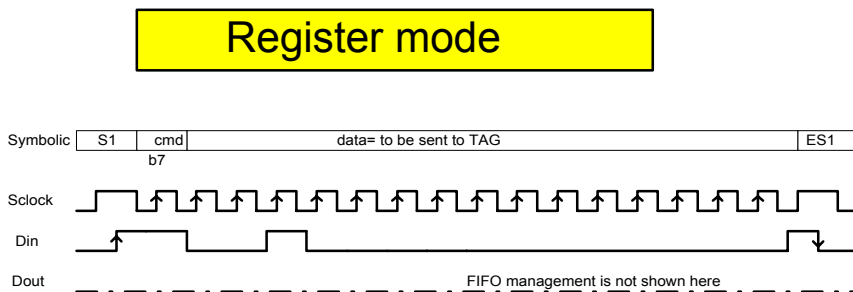

Example:

The data stream to address the RF protocol as defined in the registers is given by the following sequence:

	Size/length
Start (S1)	1 Bit
Command byte	Bit #7 = if High the mode is set according to the register settings.
Data to the tag:	Arbitrary length binary data stream. The bits are encoded according to the protocol format defined in the RF protocol registers
Stop (ES1):	1 Bit

4.3 RF Protocol**4.3.1 General**

A description of the RF Protocol according to ISO 15693 and ISO 14443 can be found in the relevant ISO documentation. The Tag-it protocol for Tag-it HF transponders is described in the Tag-it protocol, TI specification 11-04-21-002.

**Notes:**

The transmission direction of the binary data depends on the definition of the selected RF Protocol and can be different between the command byte and the binary data (RF Protocol). For example: for ISO 15693 and ISO 14443 you must send the LSB first.

The binary data response for the Tag-it protocol and the ISO 15693 protocol contains two additional zeros (0 0) in the end of frame, to indicate the end of transponder transmission. This sequence is decoded as "0 0 ES". The two zeros must be removed from the data string before any further processing.

4.3.2 Direct Mode

In Direct Mode, the controller has to create all modulated signals sent to the TAG since the transmitter input is directly connected to the input line Din. This signal has the exact timing required by the TAG.

Figure 13 Direct Mode

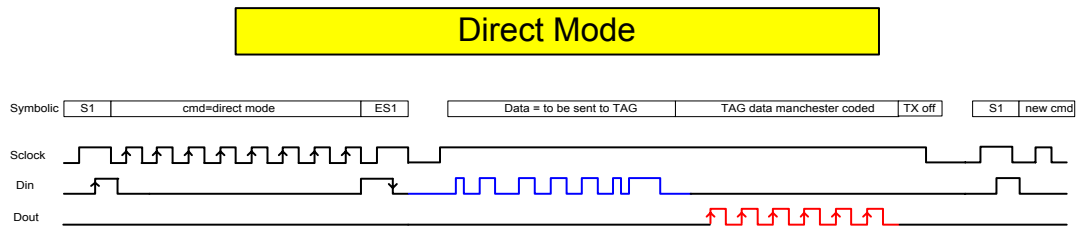

The 'Direct Mode' is entered by S1, command (8 bits), ES1 and the Transceiver IC is then set to "direct Mode". At this point, no carrier modulation has been applied to the TAG. After SCLOCK rises, DIN can directly control the modulation input, which is then directly connected to the RF modulator.

The modulation depth 10% or 100%, the receiver channel settings and the demodulation mode AM/FSK are defined by the command byte. The raw demodulated data (Manchester coded) is available at DOUT and no further processing is performed by the Transceiver IC when operating in this mode.

To exit this mode the SCLOCK line changes from high-to-low and the transmitter is switched off.

4.4 Register Configuration

4.4.1 Write Data to Configuration Register

The data bits following the command byte are written to the configuration register.

Figure 14 Write Configuration Register

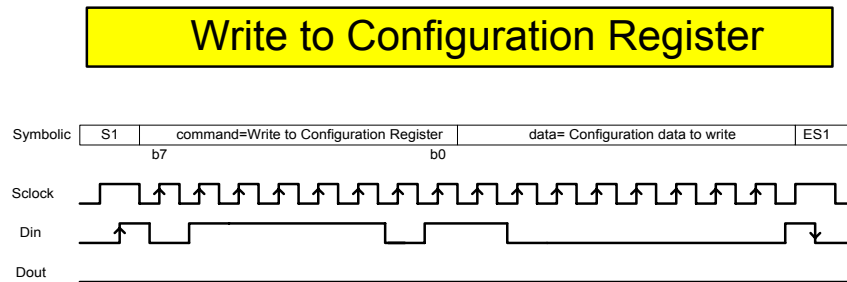

Figure 14 represents the command “Write to Configuration Register” since the 8 bits of command are 01111101. The data stream illustrated in Figure 14 is 8 bits long.

This sequence is used to define the active settings when operating in “Register mode” (see sequence “Register Mode”). The values for Bit 7 “Idle Mode” and bit 0 “Manchester Decoder” are also valid for “Normal Mode”.

After the bit ES1, the command “Write to Configuration Register” is finished. A new bit S1 is expected to initiate a new sequence.

4.4.2 Read Data to Configuration Register

Read Data from Configuration Register: The data after the command byte are the content of the registers and clocked out by the SCLOCK from the controller.

Figure 15 Read from Configuration Register

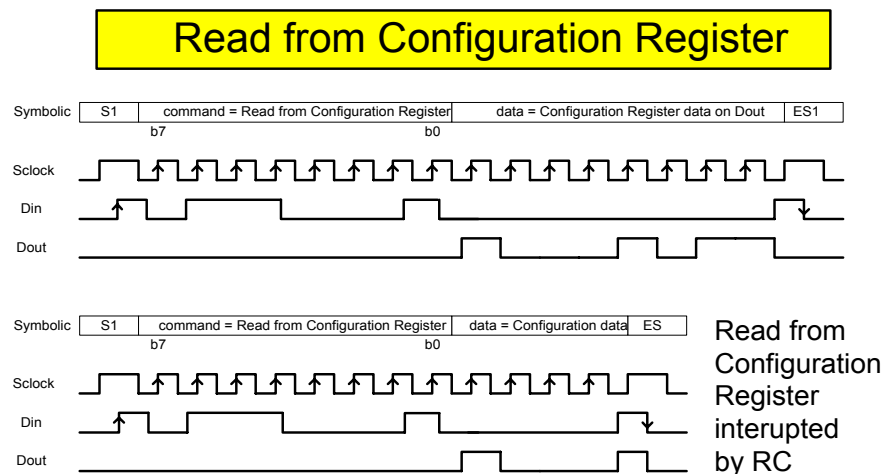

Figure 15 shows the “Read from Configuration Register” command, which is 01110001. The controller is reading the configuration register of the Transceiver IC. This has nothing to do with the presence of a TAG or not. The controller can consider this operation as reading a RAM via the three wires serial link interface. The controller is allowed to send ES1 before having read all configuration bits if it does not need to know all bits. The order of the configuration bits inside the Transceiver IC is then important in case a specific part of the configuration is read frequently.

After the bit ES1, the command “Read from Configuration Register” is finished. A new bit S1 is expected to initiate a new sequence.

4.5 Communication

4.5.1 FIFO Management

Because the micro controller cannot control the timing of sending data to the TAG the Transceiver IC must store the data from the micro controller. The capacity of storage being limited, management of the buffer must be implemented. The buffer is implemented as a 16 bit FIFO.

Figure 16 FIFO Management

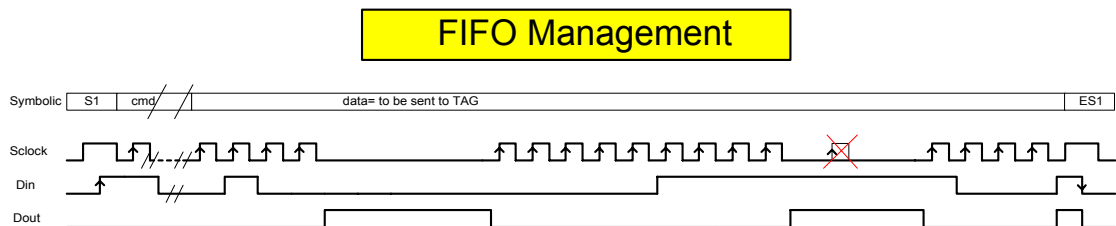

Note:

As long as DOUT is at level 1 it is not permitted to send a clock signal on the SCLOCK line.

The FIFO management is shown in Figure 16. The Transceiver IC indicates that its buffer is full and asks the controller to stop sending data. The Transceiver IC does so by raising DOUT while SCLOCK=0. The controller must wait until DOUT returns to level 0 to send further data. The Transceiver IC indicates that its buffer is almost empty under the following conditions:

Table 8 Overview of #Bits present in FIFO

Mode	# Bits present in FIFO	
	DOUT is rising	DOUT is falling
Tag-it	16	3
ISO 15693 1 out of 4	16	2
ISO 15693 1 out of 256	16	7
ISO 14443	16	3

Data is written with the commands “Write ASIC”, “Normal Mode” and “Register Mode”. The FIFO management is not needed for the “Write ASIC” command, since writing in the Transceiver IC is immediate. FIFO management will be used with the “Normal Mode” and “Register Mode” commands.

4.5.2 Basic Request / Response

The SCLOCK line becomes bi-directional.



Note:

For the sake of clarity we have introduced a new convention: When the Transceiver IC drives the line SCLOCK the start of the sequence is marked S2 and the end ES2.

DIN is always input for the Transceiver IC

DOUT is always an output for the Transceiver IC

SCLOCK is used by the Transceiver IC and the controller

Figure 17 Basic Request / Response

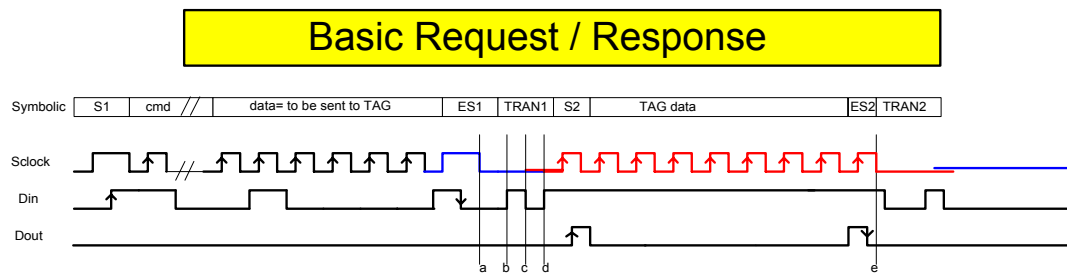

S1, cmd//, and ES1 are sent (cmd// = “normal mode” OR “register mode”). A SOF followed by the data and terminated by EOF is transmitted to the TAG by amplitude modulation of the carrier. (Remark: the FIFO management is not shown in figures 13, 15 and 17).

In a typical case, the TAG will now send its answer to the request. The ASIC has to control the line SCLOCK since the data rate of the TAG will pace the data flow.

4.5.2.1 Definition TRAN1

During Transient 1 (TRAN1), the controller gives control of the SCLOCK line to the Transceiver IC: DIN =0

- Time a: The bit ES1 is finished.
- Time b: The controller raises DIN, either to prepare a control mode change for the SCLOCK line or to prepare an ES1.
- Time c: DIN is falling. The controller definitely indicates that it will give the SCLOCK line control to the Transceiver IC. SCLOCK =0 and both the controller and the Transceiver IC are outputs.
- Time d: DIN rises showing that the controller leaves the control of the bus until DIN falls to ask the control of SCLOCK back. At time d, SCLOCK is still equal to 0 but the pin SCLOCK of the controller is an input and the pin SCLOCK of the Transceiver IC is an output.

When the Transceiver IC has control of SCLOCK, it will send a S2 that corresponds to a SOF sent by the TAG, the data (7 bits in Figure 17) and an ES2 that corresponds to the EOF of the TAG.

4.5.2.2 Definition TRAN2

During Transient 2, the controller regains control of SCLOCK: DIN =1

The controller indicates its intention to regain control over SCLOCK by setting DIN=0 and initiate a change by making a pulse on DIN. It is during this pulse that the line SCLOCK will change direction.

4.5.3 Bi-directional SCLOCK

Figure 18 shows an extreme case of successive changes of SCLOCK control. This example demonstrates the principle, its purpose is not to show a typical case. Even if this could be done, it is very unlikely that a user would implement such a case.

Figure 18 Bi-directional SCLOCK

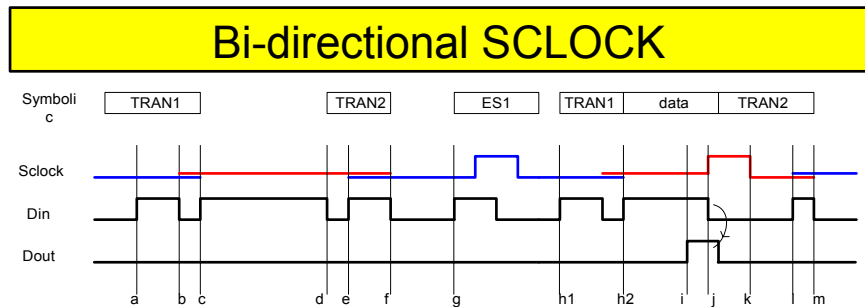

A classical TRAN1 is shown at times a, b and c of Figure 18. This is described in section 4.5.2.1.

At time d, the controller signals that it wants to take back control of SCLOCK. DIN rises at time e. Between time e and time f, SCLOCK=0 both Transceiver IC and controller are outputs. At time f, only the controller is an output.

At time g, the controller raises DIN to prepare an ES1.

Between time h1 to h2, a classical TRAN1 is performed. At time h2, the Transceiver IC controls SCLOCK.

At time i, the Transceiver IC raises DOUT to be ready to send a data '1' to the controller as SCLOCK is rising. At the same time (before or after), the controller resets DIN showing it wants to take back the bus.

The falling of DOUT while SCLOCK=1 is normally an ES2.

At time k, the Transceiver IC resets SCLOCK to low. After this a TRAN2 can take place. At time l, both Transceiver IC and controller are outputs. At time m, the Transceiver IC is an input and the controller is an output.

4.5.4 Simultaneous Identification (SID) / Anti-collision

Figure 19 Simultaneous Identification (SID) / Anti-collision

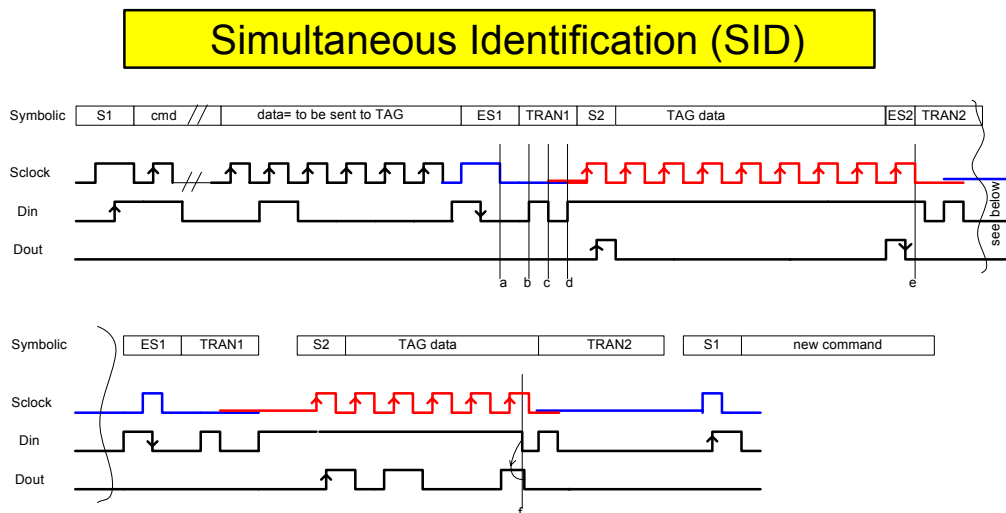

When you have read section 4.5.3 you (controller software developer) have all the elements to establish a SID with the TAG, this is shown in Figure 19.

The sequence S1, cmd//, data, ES1, will send to the TAG a SOF, Data (=SID request), EOF. The last EOF can normally be seen as the marker of the beginning of the first slot. The first TRAN1 allows the Transceiver IC to send the data received from the TAG. The first bit sent is S2 (corresponding to a SOF sent by the TAG), TAG data (7 bits on Figure 19), ES2 (corresponding to the EOF sent by the TAG). A TRAN2 gives back the SCLOCK to the controller.

ES1 is then sent to modulate an EOF towards the TAG, delimiting a new slot. The next signals are TRAN1, S2, TAG data (only 4 bits) but at this time, the controller is not interested in continuing to read data. At time f, the controller resets DIN to ask for control of SCLOCK. The Transceiver IC stops the process TRAN2 since SCLOCK='1' by resetting DOUT. As soon as SCLOCK='0', the Transceiver IC acknowledges it is ready to begin a TRAN2 by raising DOUT='1'. A TRAN2 can now take place to give back the control to the controller.

Finally, the controller decides to start a new sequence by sending S1, which completes the SID sequence.

The two slots shown, as an example, are not typical since 16 slots may be used in normal operation.

4.6 Power Management

4.6.1 Idle Mode

The Transceiver IC can be switched to Idle mode by configuring Bit 7 of the Configuration Register to 1 with the command "Write to Configuration Register". In this mode, only the oscillator and the essential digital circuits are enabled. It can be switched out of Idle mode by configuring Bit 7 of the Configuration Register to 0.

4.6.2 Power Down Mode

The Transceiver IC can be switched into "Power Down Mode" by sending the Power Down configuration command (01111110) as described in section 4.1.2 and Table 7.

In Power Down Mode, the crystal will not be running, some analog circuitry may be shut down, the carrier will be off, the configuration bits remain unchanged.

Consequently, the serial link (clocked by the crystal) will not be available. The controller cannot communicate with the Transceiver IC in this mode.

To wake the Transceiver IC up, the controller has to send a bit S1 that will trigger some asynchronous circuitry on board of the Transceiver IC. This action will reset (asynchronously) the bit 'Power Down', and will restart the crystal oscillator. After a delay of 10 ms, the serial link will operate again.

During a wake up phase, the controller will have to wait until the crystal oscillator has reached its nominal operating conditions again. The controller (after this delay) should initiate a new sequence (S1, cmd, and data, ES1). Note that the bit S1 used to wake up the Transceiver IC is not initiating a sequence. In practice, to write a new sequence to the Transceiver IC when the Transceiver IC is in Power Down Mode, the controller must do: S1, delay (10 ms), S1, cmd, data, ES1 (where cmd can be any command).

4.7 Pin M_ERR

The pin M_ERR is an output and has three functions:

- It will rise during ES1 if the bit #0 (parity) is wrong in the command
- It will rise as soon as bad data is decoded by the Manchester decoder while receiving data. This tells the controller that the common bits of two Tags answered at the same time within the same slot or the timing offset for synchronizing of the Manchester decoder needs to be adjusted (see Appendix C - Timing Register).
- If the FIFO Buffer is empty and the reader to transponder communication is finished then a 22 μ s pulse is generated on the M_ERR pin.

Regulatory, Safety and Warranty Notices

This chapter provides important safety precautions and safety regulations.

Topic	Page
5.1 Regulatory, Safety and Warranty Notices.....	39
5.2 Warranty and Liability	39

5.1 Regulatory, Safety and Warranty Notices

An RFID system comprises an RF transmission device, and is therefore subject to national and international regulations.

Prior to operating the S6700 Transceiver IC as a system together with antenna(s) and power supply, the required FCC, PTT or relevant government agency approval must be obtained.

Sale, lease or operation in some countries may be subject to prior approval by the government or other organization.

5.2 Warranty and Liability

The "General Conditions of Sale and Delivery" of Texas Instruments Incorporated or a TI subsidiary apply.

Warranty and liability claims for defect products, injuries to persons and property damages are void if they are the result of one or more of the following causes:

- improper use
- unauthorized assembly, operation and maintenance
- operation of with defective and/or non-functioning safety and protective equipment
- failure to observe the instructions given in this document during transport, storage, assembly, operation, maintenance and setting up
- unauthorized changes to the product
- insufficient monitoring of the IC' operation or environmental conditions
- repairs
- catastrophes caused by foreign bodies and acts of God.

Application Examples

An Application Schematic which has been optimized to drive a 50 Ω resistive antenna using a 5 V power supply is shown in Figure 20.

Figure 20 Application Circuit

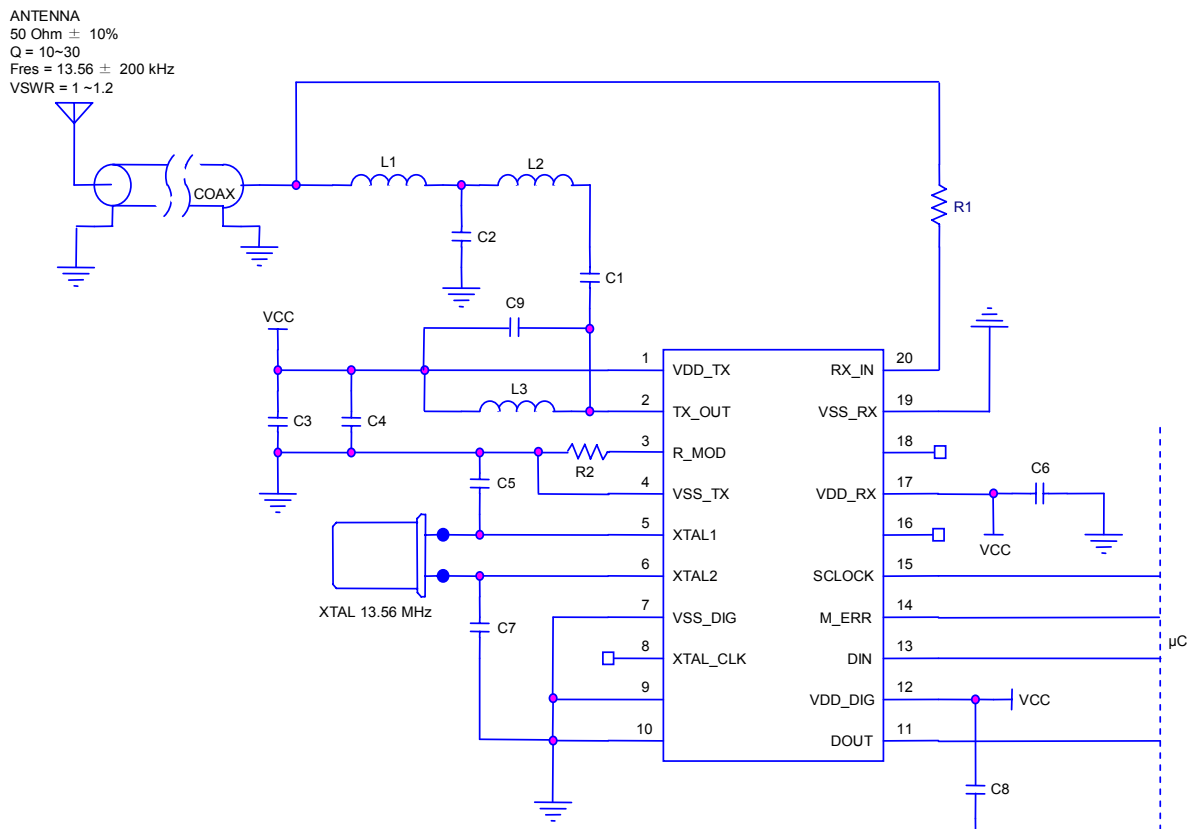

Table 9 Part List for Application Circuit

Component	Value	Component	Value
C1	10nF	L1	4.2 μ H
C2*	56pF	L2	5.6 μ H
C3	10 μ F Tantalum	L3	3.3 μ H
C4	100nF	-	-
C5*	22pF	R1	2.2k Ω
C6	100nF	R2	18 Ω
C7*	22pF	-	-
C8	100nF	-	-
C9*	47pF	-	-

Note:

For devices marked with * , Class I (COG, NPO) ceramic type capacitors should be used.

Recommended inductance parameters:

Q factor: 20 to 40

Self resonant frequency: > 27MHz

At 5 V, this circuit will output typically 200 mW RF power when a suitable matched 50 Ω antenna is connected. At 3 V the output will be typically 80 mW RF power. Connecting a more simple resonating circuit results in lower output power.

Where the transmitter is intended to be on all the time, it is recommended that the chip pad sizes and tracks are increased to provide a larger area for heat dissipation.

Care should be taken with board design to avoid excessive capacitance. When board capacitance is too high, the value of the capacitance associated with the crystal may need reducing to avoid an unstable clock. The suggested circuit shows capacitor values of 22 pF.

The Transceiver IC can be switched from 100% to 10% via the software. ISO 15693 specifies that the inlay should perform with modulation depths between 10% and 30% (in addition to 100%) and the required depth can be configured by changing resistor R2 in the suggested circuit. Table 10 shows the resistance values required in to change the depth of modulation.

Table 10 Modulation Resistor Values

Modulation%	Resistor Value (Ω)	Comment
10	12	Minimum modulation depth
20	18	Recommended modulation depth
30	25	Maximum modulation depth

**Note:**

In order to achieve the highest possible read-out coverage we recommend that you operate the reader at a modulation depth of 20% or higher.

Command Byte Overview

An overview of the Transceiver IC's Command Byte is shown on the next page.

Command Byte

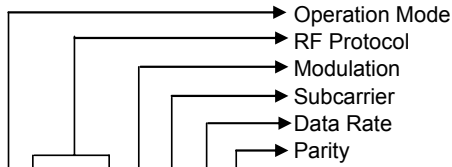

0=Normal Mode
 0=10% , 1=100%
 0=FM (two subcarrier) , 1=AM (one subcarrier)
 0=Low Data Rate , 1=High Data Rate
 set Parity to have EXOR(bit7..0)=0

								RF Protocol	Modulation	Subcarrier	Data Rate
0	0	0	0	0	0	0	0	not applicable			
0	0	0	0	0	0	1	1	Direct Mode	10%	FM	----
0	0	0	0	0	1	0	1	Direct Mode	10%	AM	----
0	0	0	0	0	1	1	0	not applicable			
0	0	0	0	1	0	0	1	not applicable			
0	0	0	0	1	0	1	0	Direct Mode	100%	FM	----
0	0	0	0	1	1	0	0	Direct Mode	100%	AM	----
0	0	0	0	1	1	1	1	not applicable			
0	0	0	1	0	0	0	1	not applicable			
0	0	0	1	0	0	1	0	not applicable			
0	0	0	1	0	1	0	0	not applicable			
0	0	0	1	0	1	1	1	not applicable			
0	0	0	1	1	0	0	0	not applicable			
0	0	0	1	1	0	1	1	Tag-it Protocol	100%	FM	High Data Rate (26.69kbit/s)
0	0	0	1	1	1	0	1	not applicable			
0	0	0	1	1	1	1	0	not applicable			
0	0	1	0	0	0	0	1	ISO 15693 (1 out of 4)	10%	FM	Low Data Rate (6.67kbits/s)
0	0	1	0	0	0	1	0	ISO 15693 (1 out of 4)	10%	FM	High Data Rate (26.69 kbits/s)
0	0	1	0	0	1	0	0	ISO 15693 (1 out of 4)	10%	AM	Low Data Rate (6.62 kbits/s)
0	0	1	0	0	1	1	1	ISO 15693 (1 out of 4)	10%	AM	High Data Rate (26.69 kbits/s)
0	0	1	0	1	0	0	0	ISO 15693 (1 out of 4)	100%	FM	Low Data Rate (6.67kbits/s)
0	0	1	0	1	0	1	1	ISO 15693 (1 out of 4)	100%	FM	High Data Rate (26.69 kbits/s)
0	0	1	0	1	1	0	1	ISO 15693 (1 out of 4)	100%	AM	Low Data Rate (6.62 kbits/s)
0	0	1	0	1	1	1	0	ISO 15693 (1 out of 4)	100%	AM	High Data Rate (26.69 kbits/s)
0	0	1	1	0	0	0	0	ISO 15693 (1 out of 256)	10%	FM	Low Data Rate (6.67kbits/s)
0	0	1	1	0	0	1	1	ISO 15693 (1 out of 256)	10%	FM	High Data Rate (26.69 kbits/s)
0	0	1	1	0	1	0	1	ISO 15693 (1 out of 256)	10%	AM	Low Data Rate (6.62 kbits/s)
0	0	1	1	0	1	1	0	ISO 15693 (1 out of 256)	10%	AM	High Data Rate (26.69 kbits/s)
0	0	1	1	1	0	0	1	ISO 15693 (1 out of 256)	100%	FM	Low Data Rate (6.67kbits/s)
0	0	1	1	1	0	1	0	ISO 15693 (1 out of 256)	100%	FM	High Data Rate (26.69 kbits/s)
0	0	1	1	1	1	0	0	ISO 15693 (1 out of 256)	100%	AM	Low Data Rate (6.62 kbits/s)
0	0	1	1	1	1	1	1	ISO 15693 (1 out of 256)	100%	AM	High Data Rate (26.69 kbits/s)
0	1	0	0	0	0	0	1	not applicable			
0	1	0	0	0	0	1	0	not applicable			
0	1	0	0	0	1	0	0	not applicable			
0	1	0	0	0	1	1	1	not applicable			
0	1	0	0	1	0	0	0	not applicable			
0	1	0	0	1	0	1	1	not applicable			
0	1	0	0	1	1	0	1	not applicable			
0	1	0	0	1	1	1	0	ISO 14443 (Type A)	100%	AM	High Data Rate (105.94 kbit/s)
0	1	1	1	0	0	0	1	Read from Configuration Register			
0	1	1	1	0	0	1	0	not applicable			
0	1	1	1	0	1	0	0	not applicable			
0	1	1	1	0	1	1	1	not applicable			
0	1	1	1	1	0	0	0	not applicable			
0	1	1	1	1	0	1	1	Write to Timing Register			
0	1	1	1	1	1	0	1	Write to Configuration Register			
0	1	1	1	1	1	1	0	Power Down			

Register Definitions

Configuration Register

The Configuration Register has 8 bits which are defined as follows:

Bit

7	Idle Mode	Off=0	On=1																																				
6	RF Protocol Definition	<table border="1"> <thead> <tr> <th>Bit6</th> <th>Bit5</th> <th>Bit4</th> <th></th> </tr> </thead> <tbody> <tr> <td>0</td> <td>0</td> <td>0</td> <td>Direct Mode</td> </tr> <tr> <td>0</td> <td>0</td> <td>1</td> <td>Tag-it Mode</td> </tr> <tr> <td>0</td> <td>1</td> <td>0</td> <td>ISO 15693 / down link 1 out of 4</td> </tr> <tr> <td>0</td> <td>1</td> <td>1</td> <td>ISO 15693 / down link 1 out of 256</td> </tr> <tr> <td>1</td> <td>0</td> <td>0</td> <td>ISO 14443 Mode A</td> </tr> <tr> <td>1</td> <td>0</td> <td>1</td> <td>reserved</td> </tr> <tr> <td>1</td> <td>1</td> <td>0</td> <td>reserved</td> </tr> <tr> <td>1</td> <td>1</td> <td>1</td> <td>reserved</td> </tr> </tbody> </table>		Bit6	Bit5	Bit4		0	0	0	Direct Mode	0	0	1	Tag-it Mode	0	1	0	ISO 15693 / down link 1 out of 4	0	1	1	ISO 15693 / down link 1 out of 256	1	0	0	ISO 14443 Mode A	1	0	1	reserved	1	1	0	reserved	1	1	1	reserved
Bit6		Bit5	Bit4																																				
0		0	0	Direct Mode																																			
0		0	1	Tag-it Mode																																			
0		1	0	ISO 15693 / down link 1 out of 4																																			
0	1	1	ISO 15693 / down link 1 out of 256																																				
1	0	0	ISO 14443 Mode A																																				
1	0	1	reserved																																				
1	1	0	reserved																																				
1	1	1	reserved																																				
5																																							
4																																							
3	Modulation	10%=0	100%=1																																				
2	Two subcarrier (FM)=0	One subcarrier (AM)=1																																					
1	Data Rate:	Low=0	High=1																																				
0	Manchester decoder: enabled=0	disabled=1																																					

The default (factory) configuration is: 00100010

Timing Register

The timing register is used to set the sampling point of the digital decoder to generate binary data from the Manchester coded data stream (Timing Offset). The time is defined from the end of transmission from the Transceiver IC to the transponder until the beginning of the response from the transponder.

D12	D11	D10	D9	D8	D7	D6	D5	D4	D3	D2	D1	D0	Default
1	1	0	0	0	0	0	1	0	1	1	0	0	Default

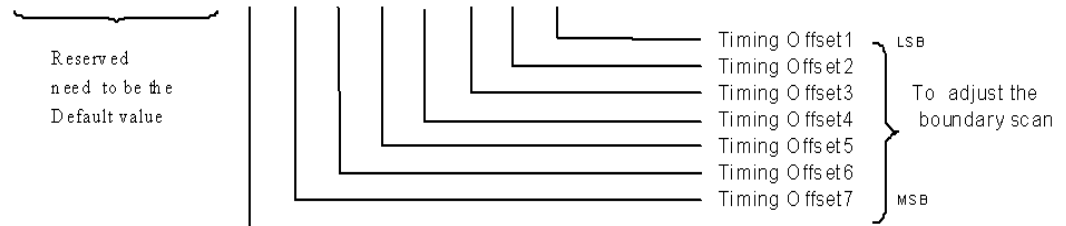

Boundary scan: 0 = Normal, 1 = Boundary scan is added on pin M_ERR

Certain variations are allowed for this timing offset and depending on the signal strength and signal-to-noise ratio seen at the receiver input a change of the default value may result in better reading results.

For test purposes the boundary scan signals can be feed to the pin M-ERR by setting bit D7.

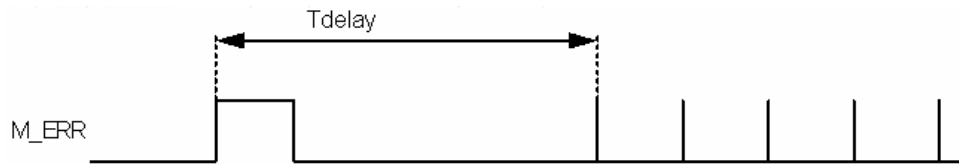

Conditions to set the timing offset:

- *Tdelay* can be altered by changing the Timing Offset Bits D6..D0.
- The weight of one bit shifts *Tdelay* by 295 ns (4/13.56 MHz).

Changing the value of this register is done with the command '0111 1011' followed by a 13-bit data stream.

Example: Set *Tdelay* to 311.31 μ s

Send command '0111 1011' followed by the 13-bit data stream '1100 0000 1001 0'.

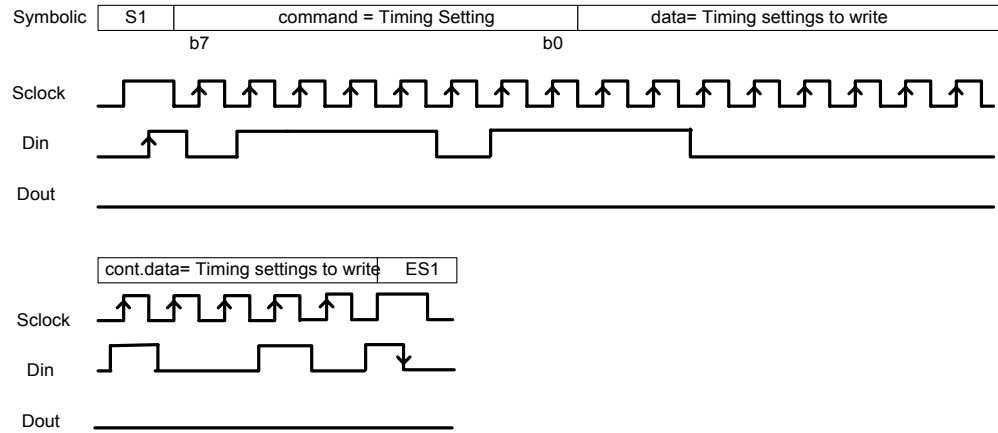

The changed setting remains active until the device is disconnected from power.

Terms & Abbreviations

A list of the abbreviations and terms used in various TI-RFid manuals can now be found in a separate manual:

Terms & Abbreviations for TI-RFid Product Manuals

Document number 11-03-21-002